

HNS410TM OWNER'S MANUAL



Scan our QR code with your phone to go directly to our website for technical information



Buttons to suit both HPM and Clipsal style wall plates included.

2-WIRE NOT SUITABLE FOR FANS, MOTORS OR IRON CORE BALLASTS



1. FEATURES

- Supports Timer and untimed ON modes of operation.
- Blue LED indicates device status.
- User programmable time-out period.
- Programmable in 1 minute increments from 1 to 30 minutes.
- When ON - Quick tap turns power off.
- Quick LED flashing within 10 seconds of time out provides expiry warning.
- Retains setting even after loss of power
- Compatible with HPM and Clipsal style wall plates.
- Remote switch compatible.
- Time set to 30 minutes out of box.

2. OPERATING CONDITIONS

- Operating Voltage: 230 – 240V a.c. 50Hz
- Operating Temperature: 0 to +50 °C (subject to ambient temperature de-rating curve)
- Compliance Standard: CISPR15, AS/NZS 3100
- Maximum Load: 400VA*
- Minimum Load: 10VA
- Maximum Current Capacity 1.7A

3. LOAD COMPATIBILITY

Incandescent	✓
240V Halogen	✓
Fluorescent Tube with electronic ballast	✓**
Fluorescent Tube with iron core ballast	x
Compact Fluorescent	✓**
Electronic Transformer	✓
LED	✓**
Wirewound Transformer	x
Fan Motors	x
Inductive Loads eg. Contactor/ Relay	x

Note: Operation at temperature, voltage or load outside of the above specifications may cause permanent damage to the unit. When used in ambient temperatures above 25°C the timer must be de-rated according to the chart.

* Check manufacturer's recommendations when putting lamps in parallel.

** Subject to manufacturers recommendations, luminaires and lamps suitable for electronic switches only.

Note: Please go to CABAC's website to see a complete list of tested compatible lamps under "Technical Data"

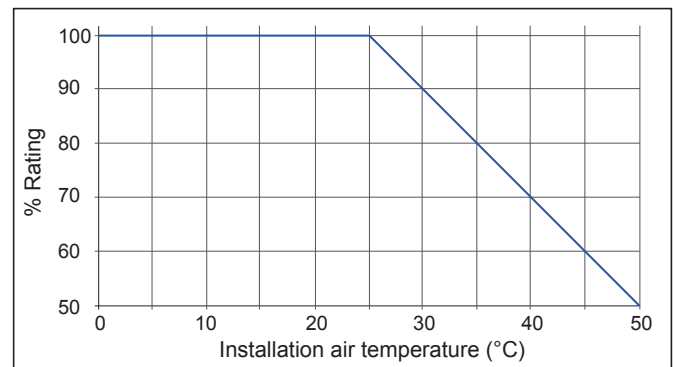

Note: This manual was correct at the time of manufacture. For the latest version of the manual and any technical or safety updates refer to the website:- cabac.com.au, cabac.co.nz or scan the QR code with a mobile phone.

4. WIRING INSTRUCTIONS

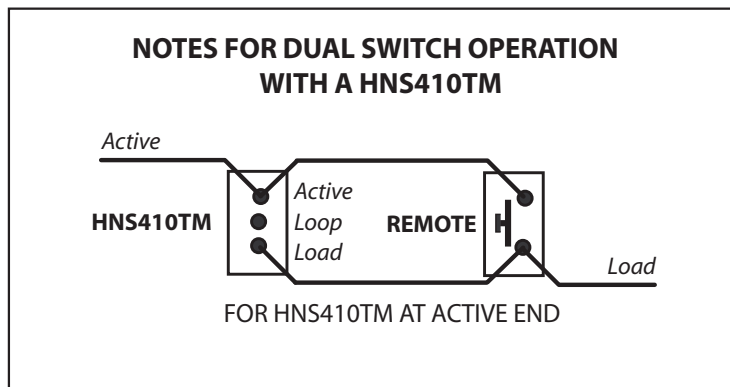
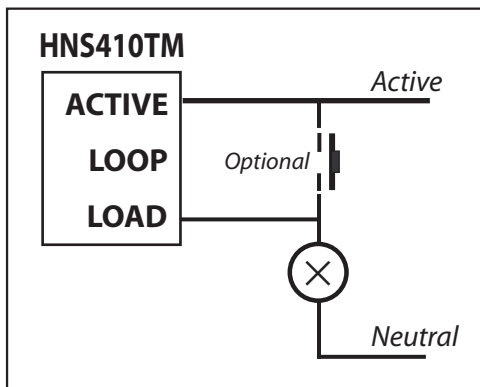

4.1 REMOTE SWITCH

- The remote switch must be a normally open 240V momentary switch.
Eg. HPM EM870K or CLIPSAL 681M20P.
- Remote wiring should not exceed 50m.
- Holding the remote switch for over 1 second will cause the HNS410TM to restart the timer delay function.
- When using the remote switch to turn the HNS410TM off- lights will flash once momentarily then switch off.
- The HNS410TM cannot be programmed using remote switch.

5. OPERATING INSTRUCTIONS

The HNS410TM employs a soft touch switch approach.

While the power is OFF there are two modes of operation that can be entered

5.1 TIMER

- A short press of the button (local or remote) will turn the unit ON.
- The LED will flash indicating the number of minutes the power will be ON before being automatically turned OFF.
- The LED will blink every 5 seconds to indicate that timer mode is operating.
- During the last 10 seconds of operation the LED will flash indicating imminent time out.
- Any time during operation, the button (local or remote) may be given another short press to cancel the timer and turn the power OFF.

5.2 NO TIMER

- A long press of the button (local only) will turn the unit ON.
- The LED be ON while the button is held in and turn OFF after 2 seconds. After the LED has been extinguished release the button.
- The LED will turn back ON and stay ON indicating that the power has no time out period and shall NOT turn OFF automatically.
- Any time during operation, the button (local or remote) may be given a short press to turn the power OFF.

NOTE: When replacing a lamp or when power is connected, the unit will be automatically turned ON in Timer mode. The power will turn OFF after the time-out period has expired or alternatively the time-out period may be cancelled with a short press of the button.

6. PROGRAMMING INSTRUCTIONS

Programming mode may be entered at any time by pushing and holding the button down for 10 seconds. The LED will flash quickly to indicate that programming mode has been entered.

To program, press the button between 1 and 30 times according to the desired delay in hours. For example, 10 presses will result in a delay of 10 minutes. More than 30 presses will result in a delay time of 30 minutes being stored. Programming mode expires 10 seconds after the last button press. At this time the new delay is stored in memory. If no button presses were detected the delay time will be unchanged.

It is only possible to enter programming mode from the local button.

7. IMPORTANT SAFETY WARNINGS

7.1 Lamp Replacement

The HNS410TM is a two wire solid state device. It should be assumed that even when OFF, mains voltage will still be present at the lamp fitting. Mains power should therefore be disconnected at the circuit breaker before replacing faulty lamps.

7.2 Installation

The HNS410TM is to be installed as part of a fixed wire electrical installation. By law such installations must be made by an electrical contractor or similarly qualified person.

7.3 Low Reading During Megger Testing

The HNS410TM is a solid state device. Therefore a low reading maybe be observed when conducting Megger testing on the circuit.

8. TROUBLESHOOTING

8.1 Lamp fails to turn ON when the button is pressed

- Ensure that the circuit has power by checking the circuit breaker.
- Check the load in another circuit to ensure it is working (The load may be incompatible with electronic switches).
- Check for a short circuit (call an electrician). The internal, non-serviceable protection fuse may have blown and if so, the HNS410TM will need to be replaced.

8.2 Lamp fails to turn OFF when the button is pressed

- If the LED is ON, check to see if it blinks every 5 seconds. Check that the button on the main unit is not being held down by dirt or grime behind the switch. If this fails to resolve the problem, cycle the power at the circuit breaker.
- If the LED is OFF and if applicable, check that the remote push button is not stuck ON. If not the HNS410TM may be damaged and should be replaced.

8.3 Power fails to time-out

- Check that the remote push button is not stuck ON.

8.4 Lamp turns back ON automatically after timing out

- Have an electrician check for sufficient mains voltage.
- Lamp is not compatible with the HNS410TM. Replace with a lamp that is suitable for electronic switches.

8.5 Lamp flickers when the button is pressed but fails to stay ON

- Lamp is not compatible with the HNS410TM. Replace with a lamp that is suitable for electronic switches.

9. WARRANTY AND DISCLAIMER

CABAC warrant the product against manufacturing and material defect from the date of invoice to the initial purchaser for a period of 12 months. During the warranty period CABAC will replace products that proved to be defective where the product has been correctly installed and maintained and operated within the specifications defined in the product data sheet and where the product is not subjected to mechanical damage or chemical attack. The warranty is also conditional on the unit being installed by a licensed electrical contractor. No other warranty is expressed or implied.

CABAC shall not be liable for any direct, indirect, incidental or consequential damages.

Note: This manual was correct at the time of manufacture. For the latest version of the manual and any technical or safety updates refer to the website:- cabac.com.au, cabac.co.nz or scan the QR code with a mobile phone.