

755WSA

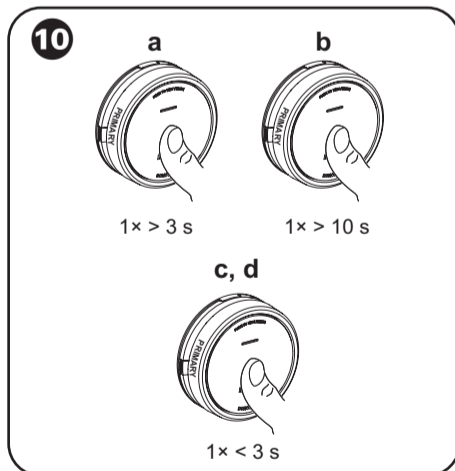

Wiser

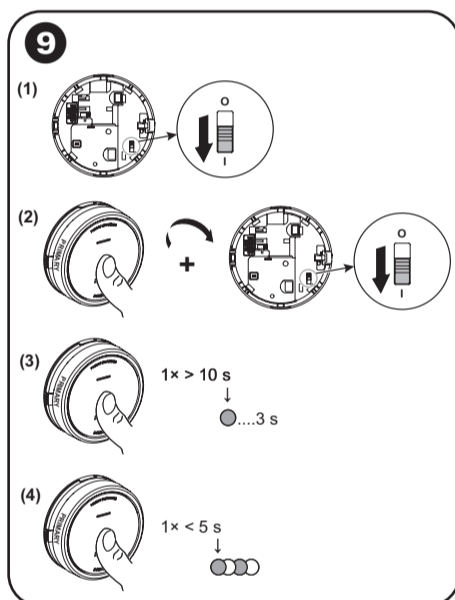
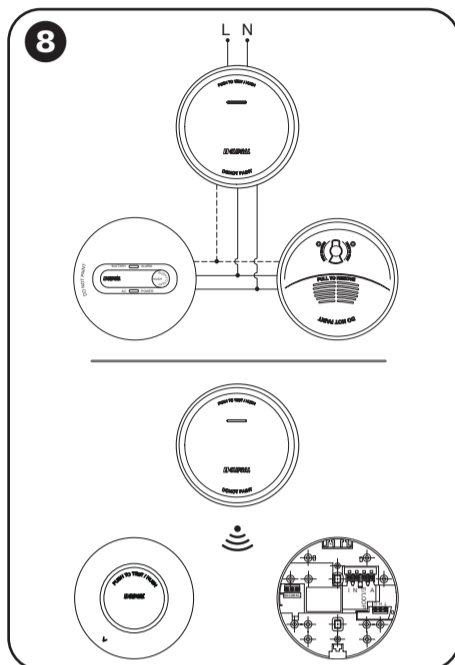
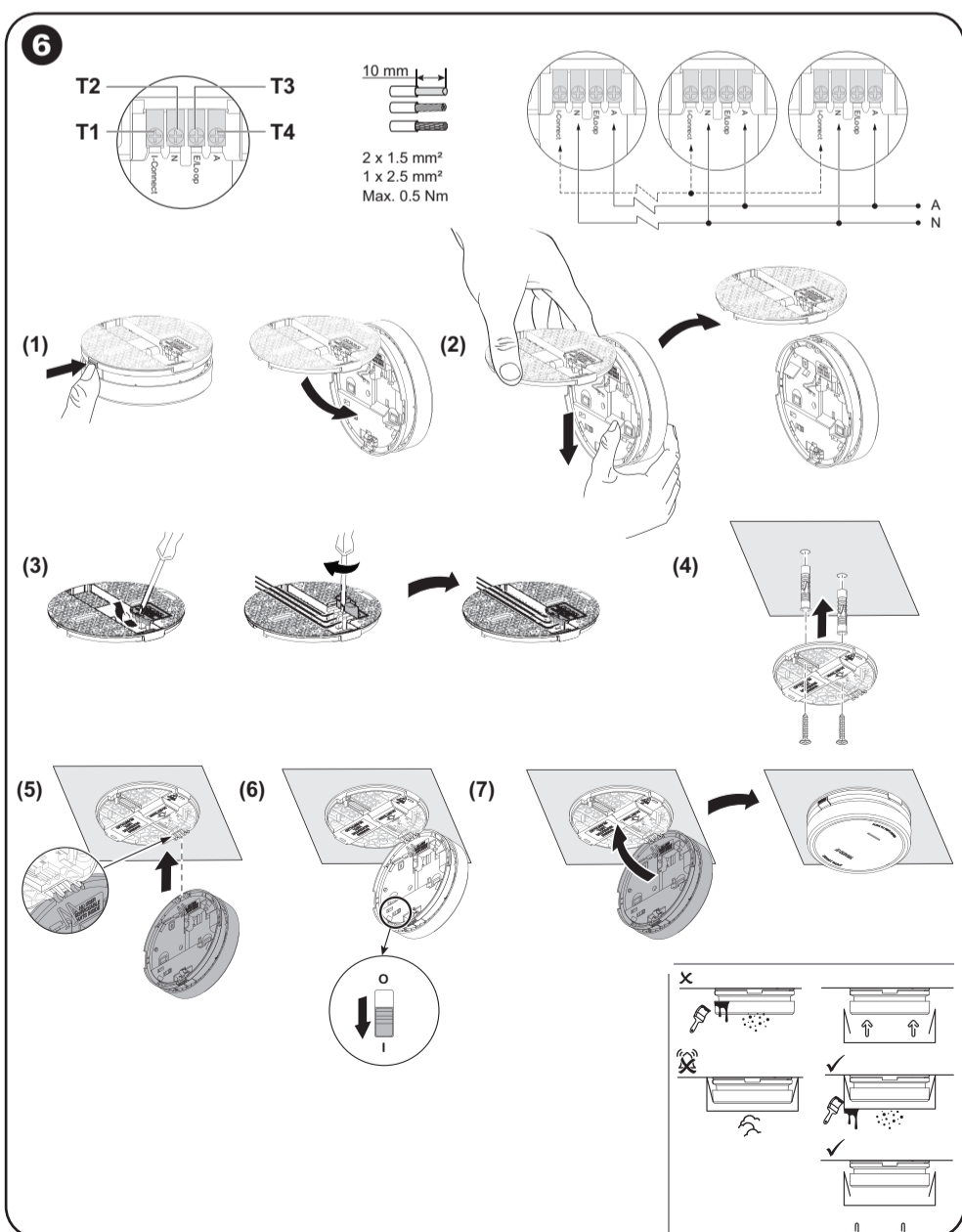
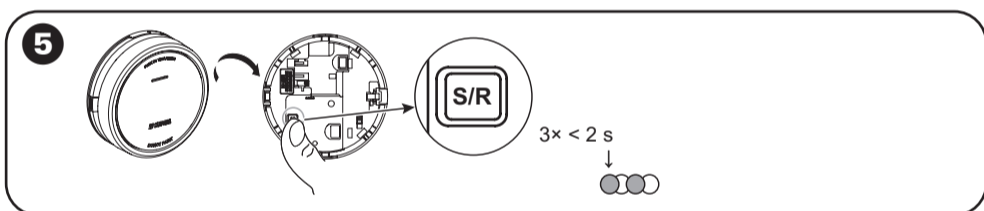
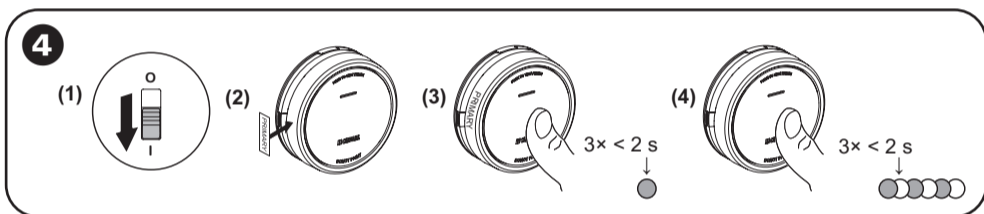
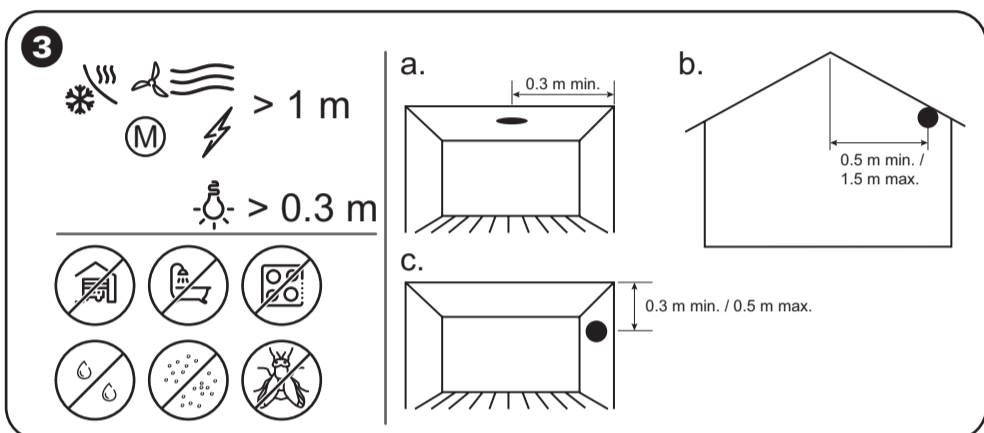
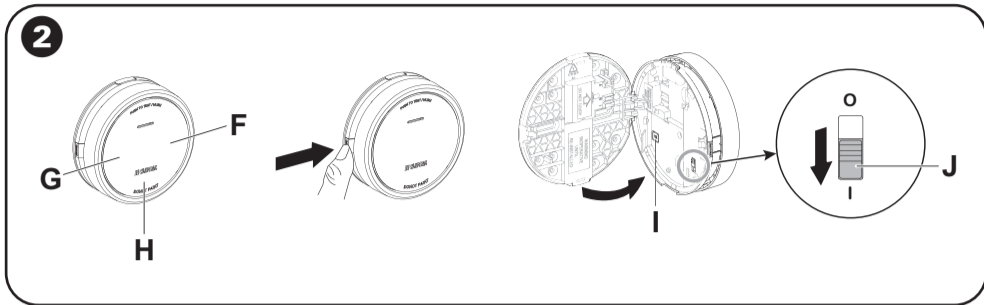
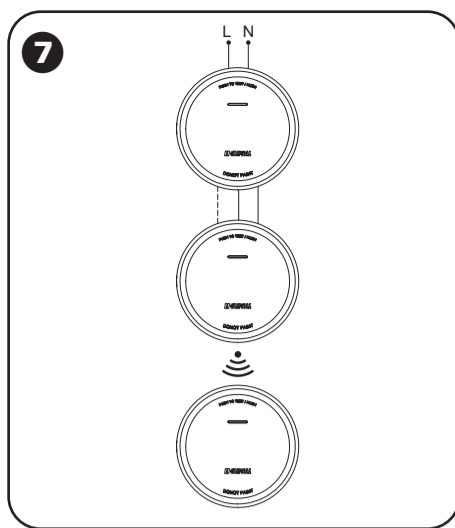
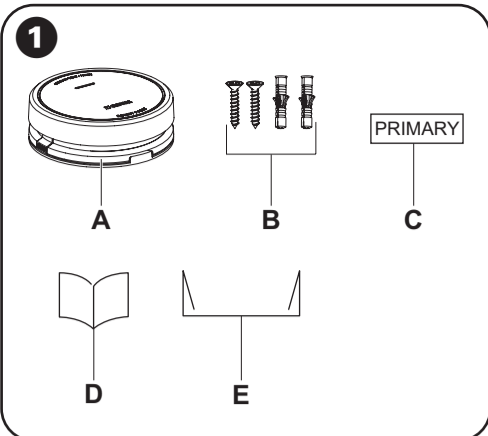

Smoke Alarm 240 V, works with Wiser

⚠️ DANGER

HAZARD OF ELECTRIC SHOCK, EXPLOSION, OR ARC FLASH

Safe electrical installation must be carried out only by skilled professionals. Skilled professionals must prove profound knowledge in the following areas:

- Connecting to installation networks
- Connecting to several electrical devices
- Laying electrical cables
- Safety standards, local wiring rules and regulations

Failure to follow these instructions will result in death or serious injury.

NOTICE

EQUIPMENT INSTALLATION HAZARD

- Always operate the product in compliance with the specified technical data.
- Keep the installation instruction for the life of the product.

Failure to follow these instructions can result in equipment damage.

⚠️ WARNING

SEALED BATTERY HAZARD

Do not recharge, disassemble or incinerate the battery.

Failure to follow these instructions can result in death, serious injury or equipment damage.

About this product

The Smoke Alarm 240V, works with Wiser (device) uses a photoelectric sensor to detect smoke generated by fire. It also includes a backup battery that allows the device to work if the power supply is disconnected. When connected to the Wiser system, the device sends notifications to the user via the Wiser app.

1 Package contents

- A Smoke Alarm 240V, works with Wiser
- B 2 Screws (M3.5 × 20 mm), 2 wall plugs
- C Primary label
- D Installation instructions
- E Dust cover

2 Operating elements

- F Status LED (Amber, Green and Red LED)
- G Standby LED (Red LED)
- H Test/Hush button
- I Setup/Reset Button
- J Power switch (Battery)

3 Choose suitable location to install

NOTICE

EQUIPMENT DAMAGE

- Do not install in garages, kitchens, bathrooms or any area with high levels of moisture, dirt or insects.
- Do not remove the dust cover until all construction work is completed. Construction dust and chemicals causes malfunction and false alarms.
- Install more than 0.3 m away from light source and 1 m away from air conditioners/heater vents and fans, electrical sources, appliances and fittings.

Failure to follow these instructions can result in equipment damage.

The device can be installed on:

- a. Flat ceiling
- b. Inclined ceiling
- c. Wall

4 Setup wireless connection without Wiser Hub

The smoke alarms (devices) can be connected to each other via RF connections even without a Wiser Hub. Read the following steps before starting the interconnection.

1. Turn the power switch to ON position on all devices.
2. Identify a device and mark it as Primary with the label supplied. Other devices are considered as Secondary.
3. Short press the Test/Hush button 3 times within 2 s on the primary device. The Standby LED turns on for 30 s once it is in pairing mode.
4. Identify a secondary device and short press the Test/Hush button 3 times within 2 s. The Standby LED blinks 3 times on both primary and secondary devices indicating successful RF connection. Then on the primary device the Standby LED again turns on for 30 s.

Repeat step 4 on all secondary devices

To ensure correct interconnection, conduct an interconnection test on all smoke alarms before and after installation.

Note: To exit from pairing mode, short press (< 0,5 s) the Test/Hush button 3 times on the Primary device. The Standby LED turns off indicating that the Primary device is not in pairing mode.

5 Connecting to Wiser Hub

Short press the setup/reset button 3 times, the status LED blinks amber. Then add the device in the Wiser app by following the instructions in the app.

When multiple smoke alarms are paired with the Wiser Hub, wireless interconnection is automatically created between smoke alarms.

To add a Wiser Hub and a Wiser Smoke alarm to an existing FireTek alarm network, the wireless interconnection must be reconfigured. Pair the Wiser Smoke Alarm with the Wiser Hub, and then pair the standalone smoke alarms with the Wiser Smoke Alarms.

For more information, refer to device user guide and system user guide.

6 Installing the device

Connection elements

T1 Wired interconnection terminal

T2 Neutral terminal

T3 Earth/Loop terminal

T4 Active terminal

⚠ ⚠ DANGER

HAZARD OF ELECTRIC SHOCK

- Make sure that the terminal connection area does not come in contact with the metallic parts of any device installed in the same location.
- When working on the device, always disconnect the device from the power supply.

Failure to follow these instructions will result in death or serious injury.

⚠ WARNING

EQUIPMENT INSTALLATION HAZARD

- All interconnected smoke alarms must be supplied from the same circuit.
- A common Neutral must be used for the Interconnect to operate.
- DO NOT connect Live or Neutral wire to terminal T3.
- Max 40 smoke alarms can be interconnected.
- DO NOT use non-pure sinusoidal power sources (e.g. power derived from square-wave invertors).

Failure to follow these instructions can result in death, serious injury or equipment damage.

- Unlock the device from the mounting base.
- Unclip the device from the mounting base to access the terminals.
- Open the terminal cover with a flat-headed screwdriver and connect the wires according to the connection diagram.
- Install the mounting base on the wall or ceiling.
- Clip the device to the mounting base.
- Turn the power switch to **I** position.
- Use light pressure to lock the device onto the mounting base.

Note: Turn on the power supply and make sure that the green LED glows on the device which indicates that the device is powered by mains power supply.

7 Set up wired connection and combination of wired and wireless connection

Important:

- A wireless connection saves wires and cables. If the devices are connected only via wires, then no additional configuration is required.
- Make sure that the wireless connection is established in all the devices before setting up a combined wired and wireless connection between the devices, for more information refer to "Setup wireless connection without Wiser Hub" in section 4.

8 Compatibility with other CLIPSAL smoke alarms

The smoke alarm (device) is compatible with other CLIPSAL smoke alarms.

Compatible devices for Wire connection: CLP599WSA, 755PSMA4, 755RLPSMA4, 755PFM4

Compatible devices for Wireless connection: 755LPSMA4, 755RFB2, CLP599WSAL and CLP599WSA

Important:

Wired connection:

- A common neutral must be used on all wired devices.
- No additional configuration is required if all devices are wired in a group.
- Wiring with 755RFB2 is not recommended.

Wireless connection:

- The wireless connection must be established on all devices according to section 4 and refer to the instructions in 755LPSMA4 / 755RFB2.
- If devices are connected to the hub, identify one as primary and consider the 755LPSMA4 / 755RFB2 as secondary.

Combined wired and wireless connections:

Follow everything mentioned in wired connection and wireless connection above.

9 Disconnecting a secondary device from RF interconnection

Note:

- Unlock a secondary device from the mounting base.
- Do not unlock the primary device.
- Read the following steps before disconnecting a secondary device.

- Make sure that the power switch is in **O** position.
- Press and hold the Test/Hush button and simultaneously turn the power switch to **I** position. The Standby LED turns on for 3 s.
- Continue to hold the Test/Hush button until the Standby LED turns off. Then release the Test/Hush button.
- Short press the Test/Hush button when the Standby LED is again turned on for 3 s. The Standby LED blinks until 5 s, indicating that the RF is disconnected. Then the Status LED blinks green 7 times indicating that the power is resuming.

Note: After disconnecting the secondary device from RF interconnection, turn the power switch to **O** position.

10 Operating the device

⚠ CAUTION

DO NOT USE OPEN FLAME

Do not use an open flame of any type to test a device.

Failure to follow these instructions can result in equipment damage.

a. Testing the device

Important: Test the device once in a month to ensure proper operation.

Press the Test/Hush button on each device for more than 3 s until an alarm goes off. If the test alarm does not go off, then the device is not connected to power supply.

b. Testing all interconnected devices by one operation

- Select an interconnected device.
- Press and hold the Test/Hush button for more than 18 s until an alarm goes off on all interconnected devices. If there is no alarm triggered on the interconnected devices, make sure that the wireless interconnection setup is correct. Also the distance between each device is within the specification.

Note: The triggered alarm on the interconnected devices remains for a longer time even if you release the Test/Hush button.

c. Silencing the device:

Hush feature

- During an alarm event, identify the device(s) which is/are blinking Red LEDs then short press the Test/Hush button on the device to stop the alarm.

Note: During the hush time, the Standby LED blinks once every 8 s.

- In an interconnected group, if more than one device has a blinking Red LEDs and active alarm, short press the Test/Hush button on all devices. All interconnected devices stops alarm within 5 to 10 s.

Temporary disablement

To temporarily disable the smoke detection in a device, short press the Test/Hush button once when the device is in Standby mode. The specific device will not be sensitive to smoke for 10 minutes. During this mode the Standby LED blinks once every 8 s.

d. Snoozing the device alerts:

• Low battery

When the battery is low, the Standby LED blinks and 1 beep occurs every 48 s. You can snooze the low battery indication for 10 hours by short pressing the Test/Hush button.

Important: The user must replace the device within 30 days from the first alert.

• Fault detection

When the battery is low, the Standby LED blinks and 2 beep occurs every 48 s. You can snooze the low battery indication for 10 hours by short pressing the Test/Hush button.

• Alarm memory

In an interconnected group, the Standby LED on the triggered device blinks once every 2 s till 72 hours after the alarm has stopped. This allows you to identify the device that was triggered.

Short press the Test/Hush button once to snooze the blinking LED for 10 hours.

11 Read full device user guide online

Scan the QR code for complete information about the device, including operation, configuration and using the product with a Wiser system.

Standby LED and alarming sound indications

	Operating mode	Standby LED	Alarming Sound	Duration
	Normal mode / Standby mode	Blinks every 48 s	OFF	—
ALARM MODE	Local alarm	Blinks every 1 s	3 beeps every 4 s	—
	Inter-connected alarm	OFF	3 beeps every 4 s	—
	Test mode	1 blink every 1 s	3 beeps every 4 s	Until Test/Hush button is released
	Wireless interconnection test	OFF	Continuous 3 beeps every 4 s	25 s
	Hush mode	Blinks every 8 s	OFF	10 min
	Low battery mode	Blinks every 48 s	1 beep every 48 s	End of life: replace the device
	Fault mode	2 blinks every 48 s	2 beeps every 48 s	Until the detected fault is cleared
SNOOZE MODE	Low battery	Blinks every 24 s	OFF	10 hrs
	Fault	2 blinks every 24 s	OFF	10 hrs
	Alarm memory	Blinks every 48 s	OFF	10 hrs

Troubleshooting

Issue	Resolution/Action
Device does not produce alarm sound when tested	<ol style="list-style-type: none"> Ensure that device is mounted correctly. Mount the device on the mounting base and turn the device clockwise until a click sound is heard. Press Test/Hush button until an alarm sound is produced. Do not press consecutively. If the problem persists or if you have questions about the warranty, contact customer care center.
Device beeps and Standby LED blinks every 48 s	Battery may be low or drained. Replace the device.
Device beeps twice and Standby LED blinks every 48 s	<ol style="list-style-type: none"> Clean the device. Refer to Maintenance section. If the problem persists or if you have questions about the warranty, contact customer care center.
Device produces alarm sound unexpectedly without smoke or steam	<ol style="list-style-type: none"> Identify the triggered device, indicated by a blinking Standby LED and 3 beeps every 4 s. Press Test/Hush button to pause the alarm sound. Interconnected device stops alarming in 5 to 10 s. Clean the device. Refer to Maintenance section. Reinstall the device and test. If the problem persists or if you have questions about the warranty, contact customer care center. <p>Note: After an alarm event, the device that has blinking Standby LED every 2 s is the triggered device. Identify the device and follow steps 3 to 5.</p>

Maintenance

It is recommended that the device is inspected monthly to ensure it is free from dirt, dust and insects. The alarm can be vacuumed or brushed with a soft brush to remove dust, dirt or kitchen grease that has accumulated. Apply a small amount of insect surface spray to a cloth and wipe around alarm/s every 3-6 months to mitigate insect ingress.

Important: Always test the device after cleaning.

NOTICE

EQUIPMENT MAINTENANCE INSTRUCTIONS

- Test the device regularly to ensure its functionality and the battery is in good condition.
- Replace the device after 10 years from the date of manufacturing.
- Do not open the device casing or repair yourself. There are no serviceable parts inside.

Failure to follow these instructions can result in equipment damage.

Technical data

Power supply	220-240 VAC, 50 Hz
Back up battery Life	10 years
Operating Current	≤40 mA
Sensing Type	Photoelectric. This alarm contains NO radioactive material.
Operating Temperature	0 °C to 45 °C
Ambient Humidity	5% to 95%
Cable interconnection	Max. 40 devices up to 150 m
Wireless interconnection	RF+Zigbee, max. 40 devices in one network
Terminal Provisions	Active, Neutral, Loop and Interconnect terminals, each accommodates 2 × 1.5 mm ² or 1 × 2.5 mm ²
Operating frequency	Zigbee: 2405 - 2480 MHz RF: 433 MHz
Wireless Range	40m indoor line of sight
Horn Level	85 dB at 3 m
Mounting Type	Mounting on ceiling and wall only
Dimensions	Ø 140 × 46 mm
Standard	AS 3786: 2014 + A1: 2015 + A2: 2018
Certification	Zigbee 3.0 RCM Activfire SAI Global

Trademarks

- Wiser™ is a trademark and the property of Schneider Electric SE, its subsidiaries and affiliated companies.
- Zigbee® is a registered trademark of the Connectivity Standards Alliance.

Other brands and registered trademarks are properties of their relevant owners.

Schneider Electric (Australia) Pty Ltd

33-37 Port Wakefield Road, Gepps Cross SA 5094

Customer Care: 13 73 28

Email: customer care.au@se.com

Warranty: <https://www.se.com/au/en/about-us/legal/terms-and-conditions.jsp>

www.se.com