

2 Introduction

2.1 Product Information

The smoke alarm (hereinafter referred to as the device) is designed to continuously monitor smoke concentration. Using an advanced split-spectrum photoelectric chamber and a built-in high-volume buzzer, it is sensitive, responds quickly and offers stable performance with few false alarms. Once the surrounding smoke concentration reaches the alarm value, it will promptly send out visual and audible alarm signals to warn the user to take immediate action. Through a wired connection, up to 24 alarms can be interconnected, forming an interlinked network. Once one device triggers an alarm, the alarm signal will be pushed to every alarm in the interconnected network, and they will all trigger an alarm together. This product is designed for residential applications such as family homes, townhouses or apartments, for locations such as living rooms, studies, bedrooms and corridors/hallways. The Device can also be fitted with an optional interconnection module (GTRFM) allowing wireless interconnection to other GT High Performance smoke, heat and CO alarms.

2.2 Product Profile

Figure 2-1 Alarm with replaceable battery back-up (GT240 model)

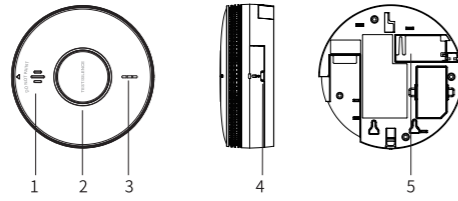

V1.0.0

Figure 2-2 Alarm with rechargeable battery back-up (GT240L model)

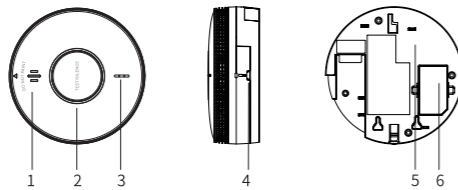

No.	Name	Introduction
1	Buzzer	Alarm Sound: 85 dB (A) at 3 m (9.84 ft) according to ISO 7731
2	Test/Silence Button	<ul style="list-style-type: none"> Verify normal operation Stop the alarm sound
3	LED Indicator	<ul style="list-style-type: none"> Power on: Red LED flashes once Standby: Green LED is constantly on Alarm: Red LED flashes once per second Sensor Fault: Yellow LED flashes twice per minute Low battery backup fault: Yellow LED flashes once per minute
4	Alarm Removal Latch	Remove the alarm from the mounting plate
5	Battery Compartment	<ul style="list-style-type: none"> Built-in battery (GT240L model only) 9 V alkaline battery (user replaceable - GT240 model only)
6	RF Module Port	Extension port for optional Wireless Interconnect module (GTRFM)

3 Technical Information

Specification	Introduction
Sensor Type	Photoelectric
Supply Voltage	110 – 250 V AC, 50/60 Hz

Mains Powered Photoelectric Smoke Alarm (GT240 & GT240L)

User's Manual

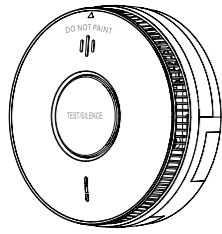

1 Important Safeguards and Warnings

The manual will help you to use the device properly. Read the manual carefully before using the device and retain it for future reference.

Operation Requirements

WARNING

Never ignore any alarm. Failure to respond may lead to serious injury or death.

CAUTION

- Make sure that the power supply of the device works properly before use.
- Use the device according to the operating environment.
- Only use the device within the rated power range.
- Transport, use and store the device under allowed humidity and temperature conditions.
- Prevent liquids from splashing or dripping on the device. Make sure that there are no objects filled with liquid on top of the device to avoid liquids flowing into it.
- The smoke alarm is designed to detect and indicate the presence of smoke, but it cannot detect gas, heat or flames.

Installation Requirements

WARNING

- Failure to properly install and operate this device will prevent proper operation of the device and will prevent its response to fire hazards.
- The device must be installed by a qualified electrician in accordance with AS/NZS 3000.

CAUTION

- Observe all safety procedures and wear required protective equipment provided for your use while working at heights.
- Ground the earthing portion of the device to improve its reliability.
- Do not expose the device to direct sunlight or heat sources.
- Observe all safety procedures and wear required protective equipment provided for your use while working at heights.
- Do not expose the device to direct sunlight or heat sources.
- Make sure the application scenario conforms to installation requirements. Contact your place of purchase or GT High Performance Smoke Alarms customer service if there is any problem.
- All installation and operations shall conform to your local electrical safety requirements, fire protection regulations, and other relevant regulations.

Maintenance Requirements

- Do not clean the device with any cleaning products.
- Do not paint the device. Paint will seal the vents and interfere with the sensor's ability to detect smoke.

Specification	Introduction
Battery Back-up	<ul style="list-style-type: none"> Non-replaceable 10-year rechargeable lithium battery (GT240L model only) Replaceable 9 V Alkaline battery (GT240 model only)
Alarm Method	Visual and audible alarm
Alarm Type	Smoke alarm, fault warning, low battery warning
Alarm Volume	85 dB (A) at 3 m (9.84 ft) according to ISO 7731
Pre-Set Alarm Value	0.2 dB/m – 0.3 dB/m
Operating Temperature	-10 °C to +55 °C (+ 14 °F to + 131 °F)
Operating Humidity	< 95% RH (non-condensing)
Silencing Function	Yes
Silence by IR Remotes	Supported (any working IR remote controller)
Indicator Light	Alarm, fault and operation indicator
Maximum Number of Interconnected Units	24 hardwire interconnected
Detecting Area	When the height of the space is less than 8 m (26.25 ft), the protection area of a device is 20 m ² -40 m ²
Dimensions	< Ø148.6 mm x H55.5 mm (Ø5.85" x H2.19")
Weight (with battery)	330 g (0.73 lb)
Certification	AS 3786:2014 + A1:2015 + A2:2018, RCM, ActivFire®

4 Device Installation

4.1 Packing List

Check the package according to the following checklist. If you find device damage or anything missing, contact the supplier.

Table 4-1 Checklist

Name	Quantity
Smoke Alarm	1
Self-tapping Screw	2
Dust Cover	1
Mounting Plate	1
User's Manual	1

4.2 Installation Position

CAUTION

This device is intended for use in ordinary indoor locations of residential dwellings. Construction and layout of individual dwellings will vary, so this should be regarded as a reference only. For further guidance, please check with your local fire authority.

Figure 4-1 Overall layout

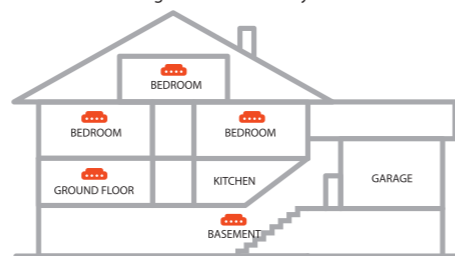

- Installed on the ceiling. If the device is installed on the ceiling, install at a distance of 300 mm away from the corners of the room.

Figure 4-2 Installation position (1)

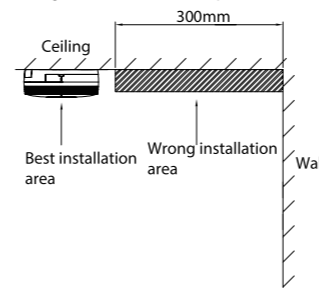
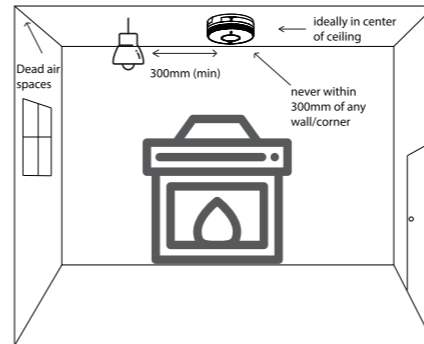
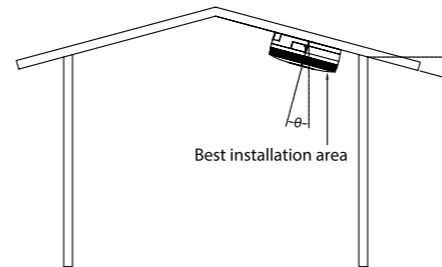

Figure 4-3 Installation position (2)



- Installed on the sloping roof. When the slope is less than 45°, the appropriate distance is 500 mm (20 inches).

Figure 4-4 Installation position (3)



4.3 Installation Steps

Follow below steps to install the device properly.

- Choose a suitable place to install your smoke alarm, and disconnect the AC mains supply from the circuit that will be used.
- Mark the positions for self-tapping screws, aligning with the power cable positions.

Figure 4-5 Installation (1)

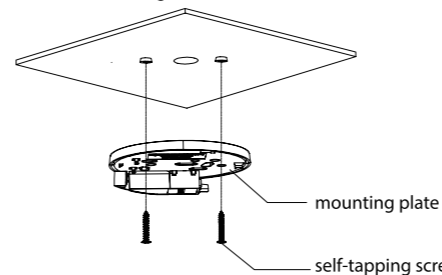

- Insert a screwdriver to lift off the wiring cover.

Figure 4-6 Installation (2)

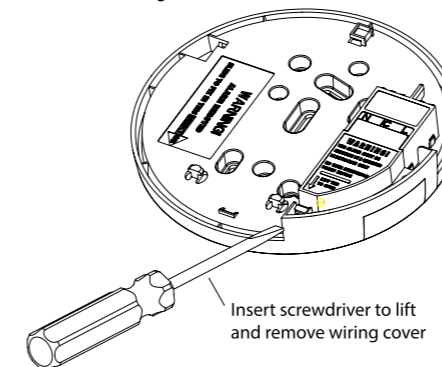

CAUTION

The wiring must be connected to the terminal block on the mounting plate as follows:

- L: Live – connect to the house wire coloured brown or marked L.
- N: Neutral – connect to the house wires coloured blue or marked N.
- IC: Interconnect – connect all circuit terminals for alarm interconnection (see Section 5 Interconnection).
- Wiring must be installed in compliance with AS/NZS 3000.

WARNING

Mixing (or poorly terminating the Live and Neutral connections may damage all alarms.

- Fix the mounting plate to the ceiling with screws connections. Ensure all mounting plates are oriented in the same direction.
- Connect the power cables to the terminal block and tighten the screws.
 - If the mains wires are recessed, bring the wires through the rear hole in the mounting plate.
 - If the mains wires are mounted on the surface, take out the removable section for wiring. If you are not using surface wiring, the removable section must be left in place for electrical safety reasons.

Figure 4-7 Installation (3)

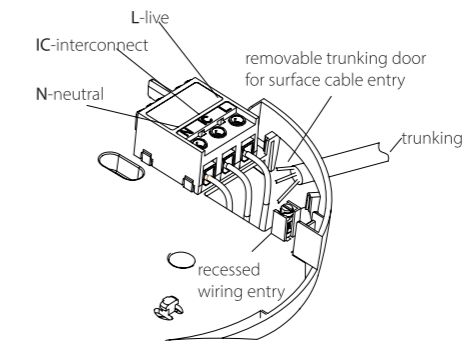
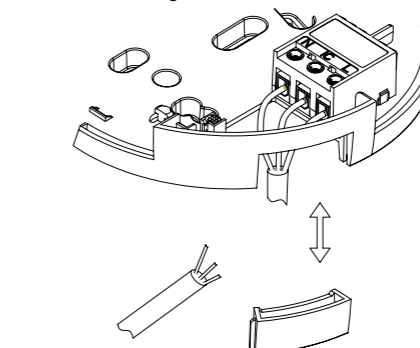
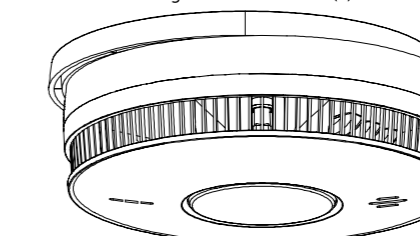

Figure 4-8 Installation (4)



- Install the wiring cover, write the installation date, and ensure that the alarm is properly aligned with the mounting plate before sliding it on according to the corresponding direction as shown in the mounting plate.

Figure 4-9 Installation (5)



- Connect the mains power to the smoke alarm circuit. Verify that the green LED indicator on the front of the alarm illuminates.
- Press and hold the **Test/Silence** button for 10 seconds, the alarm beeps. If interconnecting to other GT alarms, check that the other interconnected alarms also beep within this period. Release the **Test/Silence** button, the buzzer stops beeping immediately.

4.4 Removal Steps

Locate the arrow and slot above it on the front face of the alarm.

- Insert a flat-bladed screwdriver horizontally about 10 mm into the centre of the slot.
- Push the lower half of the alarm away from the inserted screwdriver.
- Hold the lower half of the alarm and remove it from the mounting plate.

Figure 4-10 Removal

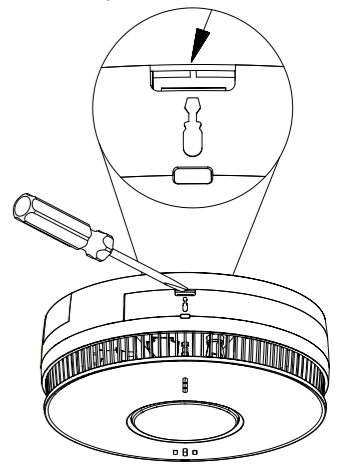

5 Interconnection

Once one device triggers an alarm, all interconnected devices will also alarm.

This device can be interconnected with other GT high Performance alarms that have interconnection capability to construct a hybrid system containing Carbon Monoxide (CO), Heat and Smoke Alarms. A maximum of 24 GT High Performance CO / Heat / Smoke Alarms can be interconnected. Warranty will be void if interconnected to any other brand or make of alarm.

Prerequisite

Make sure all alarms are powered to ensure a successful interconnection.

WARNING

- Ensure all wiring is firmly connected, otherwise, the interconnection will fail or device malfunction may occur.
- All installation and operation shall conform to your local electrical safety requirements, fire protection regulations and other relevant regulations.
- This product must be installed by a licenced electrician in accordance with AS/NZS 3000.

How to interconnect

To interconnect alarms, connect all the IC terminals together.

WARNING

- The interconnecting wire (minimum 0.75 mm² cable) must be treated as if it were Live. It should be insulated and sheathed.
- Wiring must comply with AS/NZS 3000.
- Do not exceed 250 m of connecting wire per circuit.

Figure 5-1 Interconnection

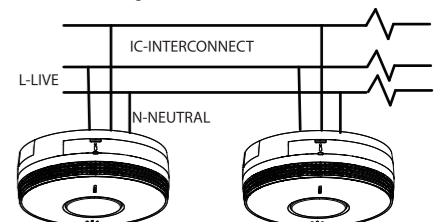

6 Test and Maintenance

After the installation of the device or regular maintenance, a test must be carried out to confirm that the device is operating properly. If any device defects are detected during the testing process, please refer to the "Frequently Asked Questions" and "Maintenance" section and retest the device. If it fails to complete the test successfully, please send the device to the manufacturer for repair.

6.1 For a single smoke alarm

Test

Press the **Test/Silence** button, the red LED indicator will flash continuously for three times and two cycles.

Silence/Pause the alarm

When the smoke concentration reaches a predetermined threshold, the LED indicator flashes and the buzzer beeps (85 dB). Press the **Test/Silence** button to temporarily mute the alarm sound and the device will be in silence mode for 9 minutes. If a false alarm is triggered, pressing the **Test/Silence** button on the device will stop the alarm sound.



CAUTION

You can silence this device with an infrared remote controller by pressing any button on it and the device will pause the alarm. The alarm will automatically exit silence mode after 9 minutes.



WARNING

If an alarm is sounding, it is warning you of a potentially hazardous situation. Do not ignore it. Ignoring the alarm may result in injury or death. If your heat or smoke alarm activates and you are not absolutely certain of the source of fire, get everyone out of the house immediately.

6.2 Maintenance

To keep your device in good working condition, please follow these requirements.

- Simulate fire alarm test: Test the device once a week. Under normal working conditions, press the **Test/Silence** button to ensure that the device can work normally. If there is a malfunction, please repair it in time. After cleaning, please install the device and test again.
- Clean the shell: Clean the device at least once per year (recommended). Keep the device free of dust or inserts by gently vacuuming the shell with a soft brush attachment when required. Avoid cleaning solutions on the device to prevent the possibility of contaminating the sensor.
- Do not paint the device. Paint will seal the vents and interfere with the sensor's ability to detect smoke.

7 Frequently Asked Questions

Problem	Solutions
Your smoke alarm does not sound during testing	<ul style="list-style-type: none"> • If testing immediately after first activating the alarm, you should allow a few seconds for the alarm to settle before testing. • Make sure you push the test button firmly.
Your smoke alarm chirps intermittently	Clean the smoke alarm (see "Test and Maintenance").
The LED indicator flashes red and the alarm sounds one beep every 60 seconds	<ul style="list-style-type: none"> • The device is under low battery condition, please replace the device immediately. • Please contact technical support for advice

8 Disposal



Waste electrical products should not be disposed of your other household waste. Please dispose in an environmentally - friendly manner, and strictly follow the local regulations regarding the disposal or recycling of the electrical device.



WARNING

Do not burn or dispose of in fire.

9 Warranty and Contact

If you need after-sales service, please contact your place of purchase, or scan the QR code below.

Australian Importer: Smoke Alarms Australasia Pty Ltd
Address: Po Box 545 Bulimba Qld 4171



    	
<p>For more information, please scan the QR code or visit https://www.gtSmokealarms.com.au</p>	