

# INSTALLATION GUIDE

# SOLAR BILLBOARD LIGHTING SYSTEM

## PRODUCT STRUCTURE DIAGRAM AND COMPONENT LIST

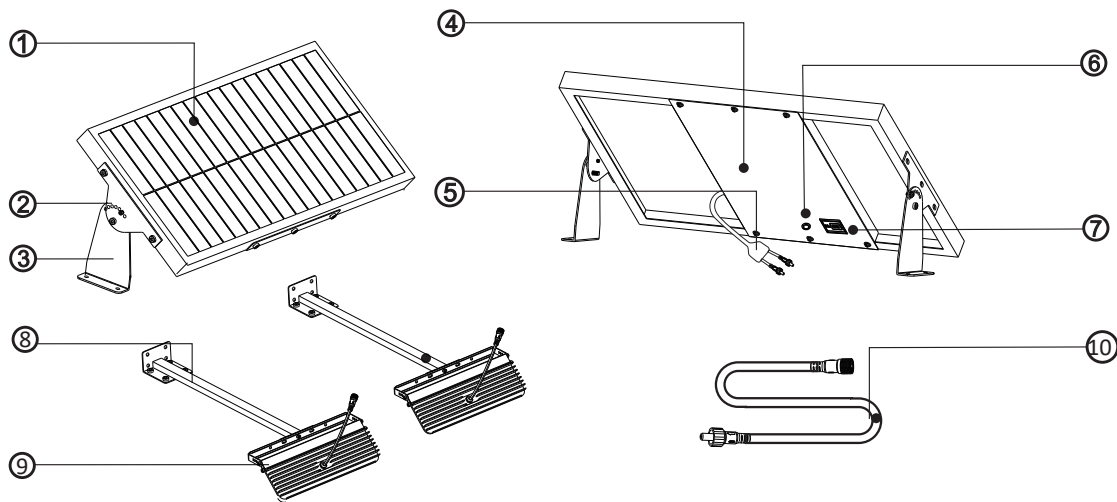

- |                            |                                      |
|----------------------------|--------------------------------------|
| ① Solar Panel              | ⑥ ON/OFF                             |
| ② Angle adjustment bracket | ⑦ Battery Power, Voltage Led Display |
| ③ Fixed bracket            | ⑧ Lamp bracket                       |
| ④ Battery compartment      | ⑨ LED light                          |
| ⑤ Output cable             | ⑩ 5-meter extension cable            |

<p>(face)</p>	<p>Angle adjustment bracket</p>	<p>Solar Panel bracket</p>
	<p>Lamp bracket (Optional)</p>	<p>(2PCS)</p>
	<p>M5*4PCS M6*2PCS M6(lamp cap)*4pcs M8*8PCS M60*16PCS Screws</p>	
<p>(Back)</p> <p>System main body (1PC)</p>		

## ASSEMBLY STEPS

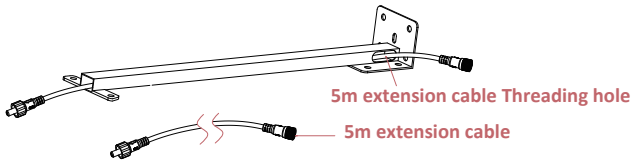

1. Feed the extension cable through the outreach mounting arm

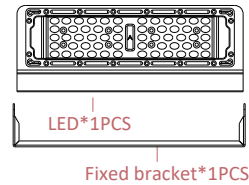

2. Place the serrated washers over the light head fixing point, then slide the mounting bracket over the serrated washer, then lock each side of the mounting bracket to the light head using the provided M5 screws

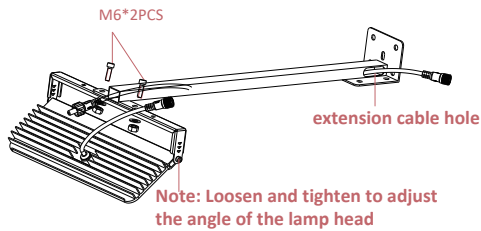

3. Fix the light head to the outreach arm using the provided M6 screws.

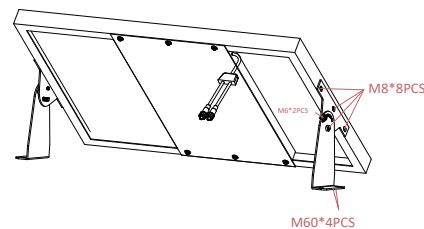

4. Fix the panel brackets to the panel and at the appropriate angle.

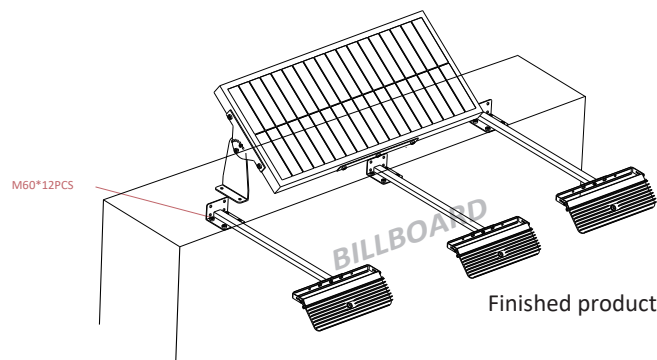

5. Fix the panel and light head outreach arms to the billboard, connect the extension cabling and turn the system on

\*The installation process for the Twin Billboard Light is identical, with the exception that it includes one fewer light.\*